

Stainless Steel Connectors (INOX)



Housings

page 138



Inserts

page 56, 94

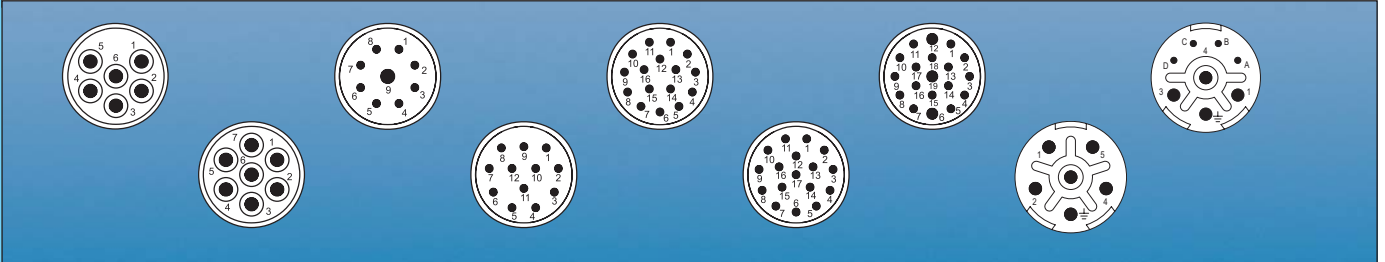

Accessories

page 63, 95



M 23 Connectors Stainless Steel (INOX)

Mechanical Data	Materials and Technical Data	
Housing	Stainless Steel V4A (AISI 316)	1.4404 (AISI 316 L)
Housing surface	Clear	
Inserts (for contacts)	Thermoplastic Polyamid PA 6 (Nylon 6/6), PBT	Fire protection class V-0
Contacts	Brass Alloy	
Contact surface at point of contact	Nickel and gold plated (0,25 µm Au)	
Minimum mating cycles	> 1000	
Seals / O-Rings	Viton (FPM), alternativ EPDM	
Temperature range	-40° C – 125° C	
Type of contacts signal M23	Crimp, solder, dip-solder (PCB)	
Type of contacts power M23	Crimp	
Protection	IP 67 / IP 69 K per EN 60 529 (connected), NEMA 4x	
Cable diameter range signal connectors	3 – 14 mm (.12 – .55")	
Cable diameter range power connectors	7 – 17 mm (.24 – .67")	

Additional Information

Electrical data see standard program

Signal Connectors M23 page 45
 Power Connectors M23 page 87

Inserts and contacts see standard program

Signal Connectors M23 page 56
 Power Connectors M23 page 94

We do not recommend disconnecting or connecting HUMMEL Connectors under load.

Typical Applications



Signal Connectors / Stainless Steel (INOX)

Straight Connector, Female Thread

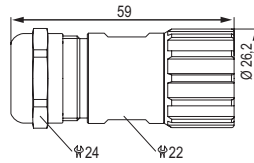

Cable-Ø

Part Number

3 – 7 mm (.12 – .28")	7.140.300.000
5 – 10 mm (.20 – .39")	7.140.400.000
7 – 12 mm (.24 – .47")	7.140.500.000
10 – 14 mm (.39 – .55")	7.140.600.000

Contacts and inserts page 56 • Assembly instructions page 142

Assembly tool 7.010.900.127 is required

Straight Connector, Female Thread, EMC

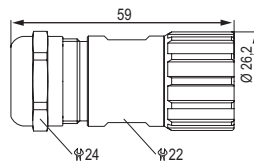

Cable-Ø

Part Number

3 – 7 mm (.12 – .28")	7.141.300.000
5 – 10 mm (.20 – .39")	7.141.400.000
7 – 12 mm (.24 – .47")	7.141.500.000
10 – 14 mm (.39 – .55")	7.141.600.000

Contacts and inserts page 56 • Assembly instructions page 142

Assembly tool 7.010.900.127 is required

Straight Connector, Male Thread

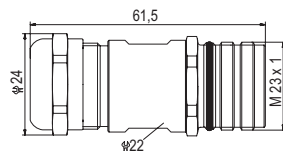

Cable-Ø

Part Number

3 – 7 mm (.12 – .28")	7.240.300.000
5 – 10 mm (.20 – .39")	7.240.400.000
7 – 12 mm (.24 – .47")	7.240.500.000
10 – 14 mm (.39 – .55")	7.240.600.000

Contacts and inserts page 56 • Assembly instructions page 142

Straight Connector, Male Thread, EMC

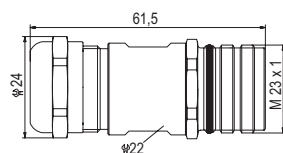

Cable-Ø

Part Number

3 – 7 mm (.12 – .28")	7.241.300.000
5 – 10 mm (.20 – .39")	7.241.400.000
7 – 12 mm (.24 – .47")	7.241.500.000
10 – 14 mm (.39 – .55")	7.241.600.000

Contacts and inserts page 56 • Assembly instructions page 142

Signal Connectors / Stainless Steel (INOX)

Type	Part Number	Panel Connector, Male Thread
With anti-vibration O-Ring 4 holes $\varnothing 3,2$ mm (.13").....7.410.400.000		
Contacts and inserts page 56 • Assembly instructions page 72		

Type	Part Number	Right Angle Panel Connector, Male Thread
4 holes $\varnothing 2,7$ mm (.11").....7.430.400.000		
Contacts and Inserts page 56		

Power Connectors / Stainless Steel (INOX)

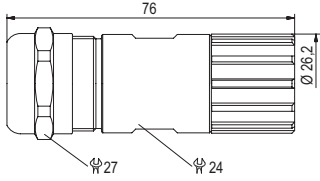

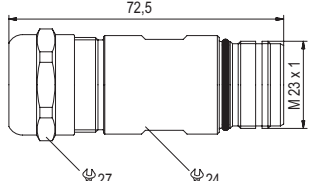

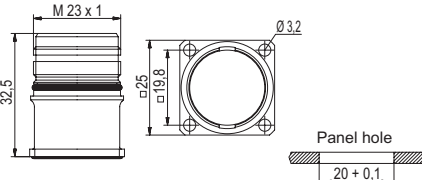

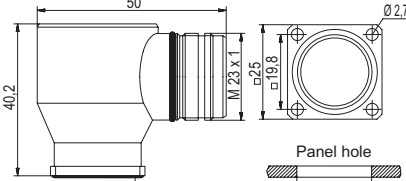
Straight Connector, Female Thread		Cable-Ø	Part Number
		7 – 12 mm (.24 – .47").....7.554.500.000	
		11 – 17 mm (.43 – .67").....7.554.600.000	
		Contacts and inserts page 94 • Assembly instructions page 105	

Straight Connector, Male Thread		Cable-Ø	Part Number
		7 – 12 mm (.24 – .47").....7.564.500.000	
		11 – 17 mm (.43 – .67").....7.564.600.000	
		Contacts and inserts page 94 • Assembly instructions page 105	

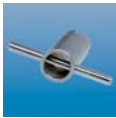
Panel Connector, Male Thread		Type	Part Number
		For front mounting 4 holes Ø 3,2 mm (.13").....7.601.400.000	
		Optional: Flat gasket	
		Contacts and inserts page 94 • Assembly instructions page 103	

Right Angle Panel Connector, Male Thread		Type	Part Number
		4 holes Ø 2,7 mm (.11").....7.630.400.000	
		Contacts and Inserts page 94	

Stainless Steel Connectors (INOX) / Accessories

Type	Part Number	Accessories
Assembly tool	7.010.900.127	
Plastic protective cap for connectors with male thread	7.000.900.101	
for connectors with female thread	7.000.900.102	
Stainless steel protective cap for connectors with female thread	7.010.904.103	
Stainless steel protective cap for connectors with male thread	7.010.904.102	
Stainless steel protective cap with rope for connectors with female threadLength 100 mm	7.010.9S4.103	
Stainless steel protective cap with rope for connectors with male threadLength 100 mm	7.010.9S4.102	
Crimp tool for manual crimping of machined crimp contacts for signal connectors	7.000.900.901	
Operating instructions on page 96		

Stainless Steel Connectors (INOX) / Assembly Instructions

Straight Connector, Female Thread

- Adapter (1) and swivel nut (4) over the cable
- Strip the cable jacket back 37 mm (3/4")
- Strip the wire ends 4 mm (5/32") max.
- Solder or crimp the contacts
- Push the contacts into the insert (6)
- Fold the spacer (5) around the wires and push it onto the insert (6)
- Push insert (6) and spacer (5) assembly into bushing (7).
- Pay attention to the desired coding (coding groove, coding key)!
- Slide assembly tool 7.010.900.127 over bushing (7), push it through the swivel nut (4) into the adapter (1) and screw it together
- Screw adapter (1) down to the stop
- Tighten the dome nut of the adapter (1) to grip and seal the cable

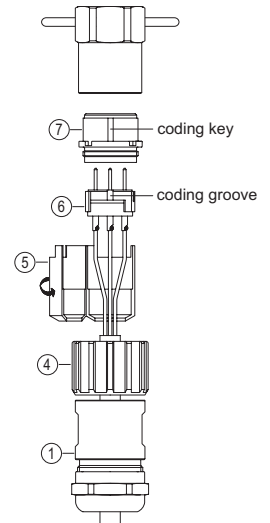

Straight Connector, EMC, Female Thread

- Adapter (1) and swivel nut (4) over the cable
- Strip the cable jacket back 20 mm (3/4"). Shorten the braided shield to 10 mm (3/8")
- Fold the braided shield over the cable
- Push the EMC ring (5) over the wires onto the braided shield.
Caution: Don't push the EMC ring behind the braided shield (Detail A)!
- Strip the wire ends 4 mm (5/32") max.
- Solder or crimp the contacts
- Push the contacts into the insert (7)
- Fold spacer (6) around the wires and push it onto the insert (7)
- Push the EMC ring (5) on the spacer (6) and fold the braided shield over the EMC ring (Detail B)
- Push insert (7) and spacer (6) assembly into bushing (8).
- Pay attention to the desired coding (coding groove, coding key)!
- Slide assembly tool 7.010.900.127 over bushing (8), push it through swivel nut (4) into the adapter (1) and screw it together
- Screw adapter (1) down to the stop
- Tighten the dome nut of the adapter (1) to grip and seal the cable

